

Preparation unit—Filter & regulator



GFR Series



Symbol

No reflux valve is attached



Reflux valve is attached

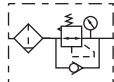

Product feature

1. Embedded square pressure gauge is used to save installation space. (External circular pressure gauge is also optional).
2. The pressed-in self-locking mechanism can prevent the abnormal movement of the set pressure caused by external interfere.
3. Balanced design is adopted for the pressure adjustment mechanism.
4. In addition to standard type, lower pressure type is optional (The highest adjustable pressure is 0.4MPa).
5. Unique diversion structure spins the air flowing through to effectively separate the liquid from the air and reliably filter the solid grain.
6. The filtering grade includes 5 μm and 40 μm (optional).
7. Three drain types are available: manual drain, semi-auto drain and automatic drain.
8. The bracket can be selected for installation.

Specification

Model	GFR200-06	GFR200-08	GFR300-08	GFR300-10	GFR300-15	GFR400-10	GFR400-15	GFR600-20	GFR600-25
Fluid	Air								
Port size	1/8"	1/4"	1/4"	3/8"	1/2"	3/8"	1/2"	3/4"	1"
Filtering grade	40 μm or 5 μm								
Pressure range	Semi-auto and automatic drain: 0.15~0.9MPa(20~130psi); Manual drain: 0.05~0.9MPa(7~130psi)								
Max. pressure	1.0MPa(145psi)								
Proof pressure	1.5MPa(215psi)								
Temperature range	-20~70°C								
Capacity of drain bowl	10CC			40CC			80CC		230CC
Weight	220g			500g			1030g		2400g

Ordering code

GFR200 08 M L F 1 W K

Model

- GFR200: G200 Series filter-regulator
- GFR300: G300 Series filter-regulator
- GFR400: G400 Series filter-regulator
- GFR600: G600 Series filter-regulator

Port size

Model	Port size
GC200	06: 1/8"
	08: 1/4"
GC300	08: 1/4"
	10: 3/8"
	15: 1/2"
GC400	10: 3/8"
	15: 1/2"
GC600	20: 3/4"
	25: 1"

Drain type

Drain type	Adaptable product's series
Blank: Semi-auto drain	GFR200, GFR300
M: Manual drain	GFR400, GFR600
A: Automatic drain	GFR300, GFR400, GFR600

Type code

- Blank: Standard
- L: Lower pressure ①

Code of reflux valve ②

- Blank: No reverse flow valve is attached
- T: NPT
- K: Reverse flow valve is attached

Thread type

- Blank: PT
- T: NPT
- G: G

Filtering grade

- Blank: 40 μm
- W: 5 μm

Scale

- 1: MPa
- 2: psi
- 3: bar

Pressure gauge shape

- F: Square
- C: Circular

Pressure gauge

- Blank: Pressure gauge
- N: No pressure gauge

Accessories

- Blank: Bracket
- J: No bracket

① The maximum work pressure of lower pressure type is 0.4MPa(58psi). ② Please refer to page 144 for details of reflux valve.

Inner structure and material of major parts

GFR200

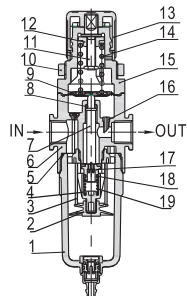

GFR600

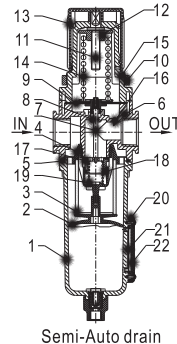

No.	Item	Material
1	Drain bowl	Aluminum alloy(GFR600)\PC(others)
2	Umbrella baffle	High viscosity POM
3	Filter core	GFR600 Agglomerated by brass grain
		others 40 μm Agglomerated by brass grain
		5 μm Makrolon fiber
4	Air guider	High viscosity POM
5	O-ring	NBR
6	Body of filter-regulator	Aluminum alloy
7	Adjusting spool	Brass (GFR600)\POM(others)
8	O-ring	NBR
9	Diaphragm	SUS304 & Rubber
10	Fixation ring cap	Aluminum alloy(GFR600)\POM(others)
11	Adjusting spindle	Steel
12	Regulator nut	Steel
13	Pressure knob	POM
14	Spring	SWC
15	Adjusting seat	Aluminum alloy(GFR600)\POM(others)
16	Feedback tube	POM
17	Adjusting plug	Brass & Rubber
18	O-ring	NBR
19	Spring	SUS304
20	Liquid meter cover	SPCC
21	Liquid meter seal	VITON
22	Liquid meter inside	PC



Preparation unit—Filter & regulator



GFR Series

Pressure and feature of flow

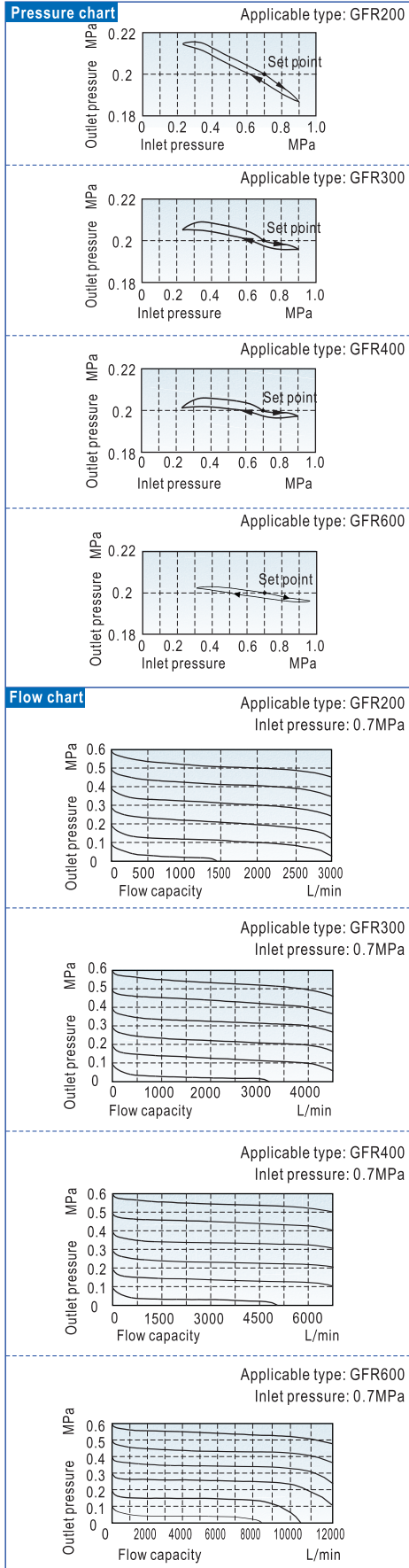

Selection of drain mode

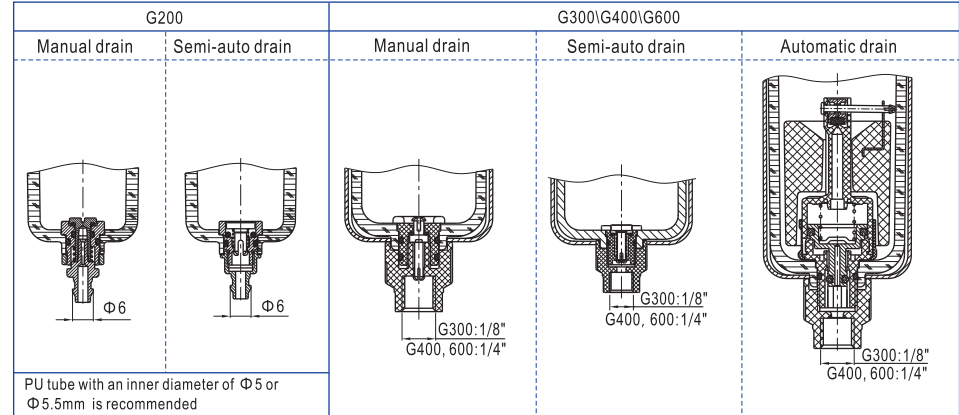

Dimensions

